

One Source

# MAAG™ WA one-stage gear unit

## For horizontal mill drives



**FLSMIDTH**  
MAAG GEAR

# Our quality policy



FLSmidth MAAG Gear is committed to creating strong lasting relationships that establish us as a trustworthy, reliable and professional partner for customers, suppliers and employees. This commitment includes providing high-quality and high-value solutions, products and services that result in satisfied customers.

### **Certified to ISO 9001 standards**

With a clear focus on process management, we endeavour not only to meet but exceed international quality standards while providing appropriate resources to support and develop our purpose-designed quality system. Our quality policies reflect the importance of meeting our customers' requirements.

Our management regularly defines and reviews quality goals. Our employees are committed to the company's management system and to continuously improving not only the system but our entire organisation. Also each employee is aware of the company vision and strategy and works to maintain a culture of opportunities.

We are committed to providing a safe working environment for our employees and for those who use our products and systems.

With our suppliers and external partners, we cultivate open communication and focus on performance-based results.

# A pioneer of modern gear technology

FLSmidth MAAG Gear was founded in 1913 and quickly expanded into an international group that now has over 100 years of experience in manufacturing gears. Since introducing the technology of mill gear units to the cement industry with great success in 1966, we have sold over 6000 MAAG™ gear units and 1000 girth gears.

## About FLSmidth MAAG Gear

At our headquarters in Winterthur, Switzerland, more than 100 employees work in development, design, finance, project management, sales, customer service and marketing. Production takes place in two modern plants equipped with high-performance machines. In Elblag, Poland and Milan, Italy, more than 200 employees manufacture gear units, drive systems and components that satisfy the strictest quality standards. The company belongs to the successful FLSmidth Group.

## Our strength

The winning combination of unique precision, accuracy and compact modular solutions produces high-efficiency products that result in low maintenance costs for customers. Experience, new technical solutions and the latest manufacturing techniques are regularly incorporated in the production process.

Our engineers attend special intensive training courses and understand not only how to operate but how to extend the lifecycle of gear units.

Constant willingness to innovate, and close collaboration with our customers help ensure that FLSmidth MAAG Gear gear units continue to operate reliably worldwide under the toughest conditions.

## Product range

Today, the FLSmidth MAAG Gear product range includes various gear units for mills, complete drive systems, gear solutions for bucket wheel excavators and belt conveyors as well as maintenance systems for all types of plant. We also manufacture components such as bevel sets, girth gears and a wide range of spare parts. All our gear units are available as standard solutions or are customised to suit customer needs.

## More information

Learn more about our products on [www.FLSmidthMaagGear.com](http://www.FLSmidthMaagGear.com).

The following QR codes will lead you directly to specific download sites:



Brochures



Videos and technical animations



# WA



## Introduction

Parallel cylindrical wheel reduction gear units, type WA, are designed for torque transmission from electric drive motors to ball, rod, SAG, AG or other types of horizontal mills. Their main purpose is to drive comminution machinery for excavated materials in the mineral processing industries. The design and manufacture of these heavy-duty industrial gear units embodies more than 100 years of experience, supported by state-of-the-art calculation methods, using simulation techniques.

Advanced manufacturing processes include the latest achievements in heat treatment and teeth machining. Precise gear-cutting machines combined with high-level control ensure the best quality of all components at all times. This is the guarantee that technical specifications are met every time, providing optimum durability, silent running and high efficiency.

## Technical description

### Gear wheels

All gears are made of case-hardened steel alloy, which ensures high strength and wear resistance of the teeth and provides light and compact construction of the gearbox. The toothing of the helical stage includes all necessary modifications to ensure smooth meshing during operation. Heat treatment and precise teeth machining result in optimal tooth contact under load conditions.

### Bearings

WA gear units run in spherical roller bearings. The type of bearing depends on the type of load

transmitted. Standard bearing durability calculations are based on Lh10 minimum 50 000 working hours.

### Gear casing

The casing is a split housing design for ease of maintenance. Casings are made of ductile cast iron or as a welded construction. To facilitate maintenance they are provided with inspection windows. They may also serve as an oil tank. Their construction ensures high quality acoustic and dynamic state. Sealing of the shafts protects the internal parts against contamination under normal operating conditions.

### Lubrication system

To maintain optimum lubrication of the gears and bearings, the gearboxes work with a stand alone pressure lubrication system that includes pumps, double filters, oil heaters, pressure transmitters, resistance temperature transmitters, thermometers, pressure gauges, etc.

### Auxiliary drive

Auxiliary or maintenance drives are available in accordance with your requirements. The auxiliary drive is fitted behind the electric motor or on the opposite side of the gear unit. The auxiliary drive is a cost effective drive used during build-up welding on the mill or for convenient positioning of the mill during maintenance. The auxiliary drive is connected to the gearbox or to the electric motor through a disengaging toothed clutch. A Kirk key interlocking system prevents the main motor and auxiliary drive from working simultaneously.

### Couplings

Our standard solution includes a flexible coupling for the high speed shaft and a toothed coupling for the low speed shaft, offering the following features:

- durable and reliable
- low operating costs
- virtually maintenance free (no lubricants that need changing)
- low vibratory loads in the drive train
- relatively wide range for axial and radial displacement

### Gearbox frame

The base plate is a welded construction with an extremely flat upper surface. It is embedded in concrete and firmly secured by anchor bolts.

### Instrumentation

The standard version gearbox is equipped with resistance thermometers, which monitor the bearings and the oil temperature. A vibration monitoring system is an additional option.

### Maintenance

Before being released, each gearbox undergoes a trial run at the factory test station. The standard version gearbox will work within an ambient temperature range of -4°C to +40°C. However, WA gearboxes can also be designed and installed for other ambient temperature ranges.

## Optional equipment

### Girth gear

The girth gear is a fabricated design made up of two or four segments. The ring where the tothing is located consists of high-quality alloy steel and is rolled and bent. The rib is made out of ordinary carbon steel and is welded to the ring. Internal stresses are eliminated by heat treatment. With these processes a homogenous crystal structure in the base material of the tothing is ensured, thereby achieving significantly higher fatigue and wear resistance compared to cast girth gears.

### Pinion

In addition to girth gear development, FLSmidth MAAG Gear also designs and develops pinions and has improved pinion technology. The correct combination of material, hardness and finishing between pinion and gear is crucial to ensuring the installed equipment has a long service life.

## Delivery conditions

### Quality guaranteed

The quality of the gear unit is at least ISO 5 / AGMA 12 and is guaranteed by the company quality assurance system, which complies with ISO 9001 (certificate SGS).

### Protective coating

All internal surfaces are covered with a protective coating that does not need to be removed before starting up the gear unit. All external parts are coated with appropriate paint without lute fillings. Protection of the gearbox is normally planned for 12 months of storage in a closed room. The protective system applied is easily adaptable to the requirements of the customer.





# Power and size

W	helical stage
A	one stage

Gear Unit Size (distance A in cm)

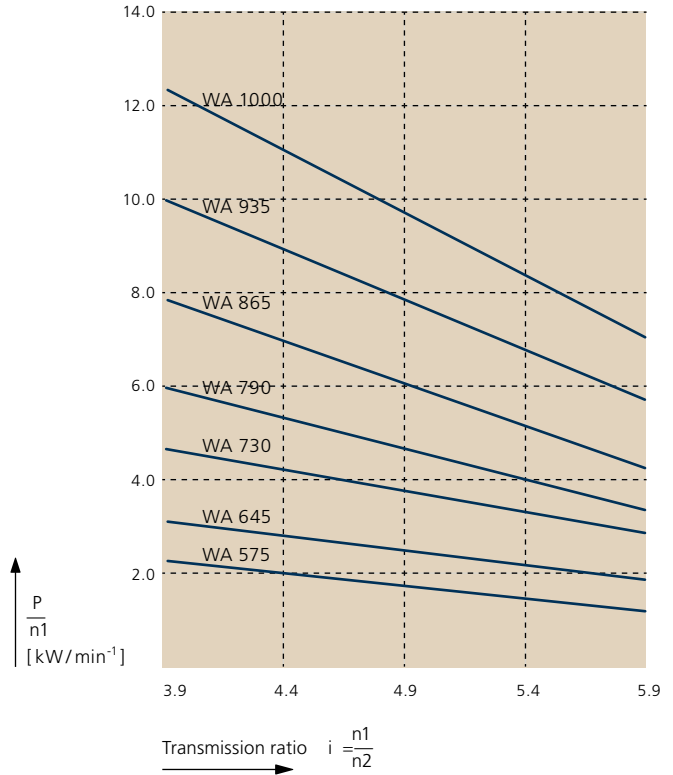
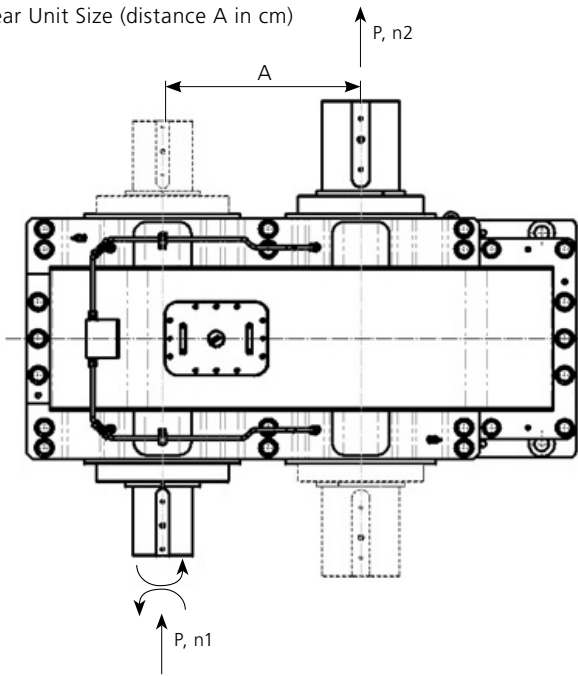

i	n <sub>1</sub> [min <sup>-1</sup> ]	n <sub>2</sub> [min <sup>-1</sup> ]	Nominal power rating [kW]*						
			WA 575	WA 645	WA 730	WA 790	WA 865	WA 935	WA 1000
4.0	1190	298	2750	3920	5580	7160	9400	11940	14690
	990	248	2300	3290	4660	5940	7800	9930	12200
	890	223	2100	2370	4200	5330	7000	8930	10980
4.2	1190	283	2650	3700	5250	6740	8900	11200	13790
	990	236	2200	3090	4380	5590	7400	9320	11470
	890	212	2000	2790	3950	5020	6650	8380	10310
4.4	1190	270	2450	3470	4915	6320	8350	10500	12900
	990	225	2000	2900	4100	5250	6950	8730	10740
	890	202	1830	2610	3700	4710	6240	7850	9650
4.6	1190	259	2290	3250	4590	5920	7800	9800	12050
	990	215	1900	2710	3840	4920	6480	8150	10020
	890	193	1700	2450	3460	4420	5830	7330	9010
4.8	1190	248	2130	3030	4280	5530	7260	9120	11220
	990	206	1770	2530	3580	4590	6040	7590	9330
	890	185	1590	2280	3230	4130	5430	6820	8390

i	n <sub>1</sub> [min <sup>-1</sup> ]	n <sub>2</sub> [min <sup>-1</sup> ]	Nominal power rating [kW]*						
			WA 575	WA 645	WA 730	WA 790	WA 865	WA 935	WA 1000
5.1	1190	233	1970	2810	3980	5140	6730	8460	10400
	990	194	1640	2350	3330	4280	5600	7040	8660
	890	175	1470	2120	3000	3850	5030	6330	7780
5.4	1190	220	1800	2610	3690	4760	6200	7830	9620
	990	183	1520	2180	3080	3960	5150	6510	8000
	890	165	1360	1970	2780	3560	4630	5850	7190
5.7	1190	209	1680	2410	3400	4380	5720	7200	8860
	990	174	1400	2020	2850	3650	4750	5990	7370
	890	156	1260	1820	2570	3280	4260	5390	6620
5.9	1190	202	1540	2250	3250	3890	5120	6500	8075
	990	168	1260	1870	2700	3350	4350	5480	6855
	890	151	1120	1680	2420	3050	3900	5000	6235

\* Rating according to AGMA standard for service factor 2 (min KSF/CSF = 2)

Other designs would be available on request.

# Dimensions

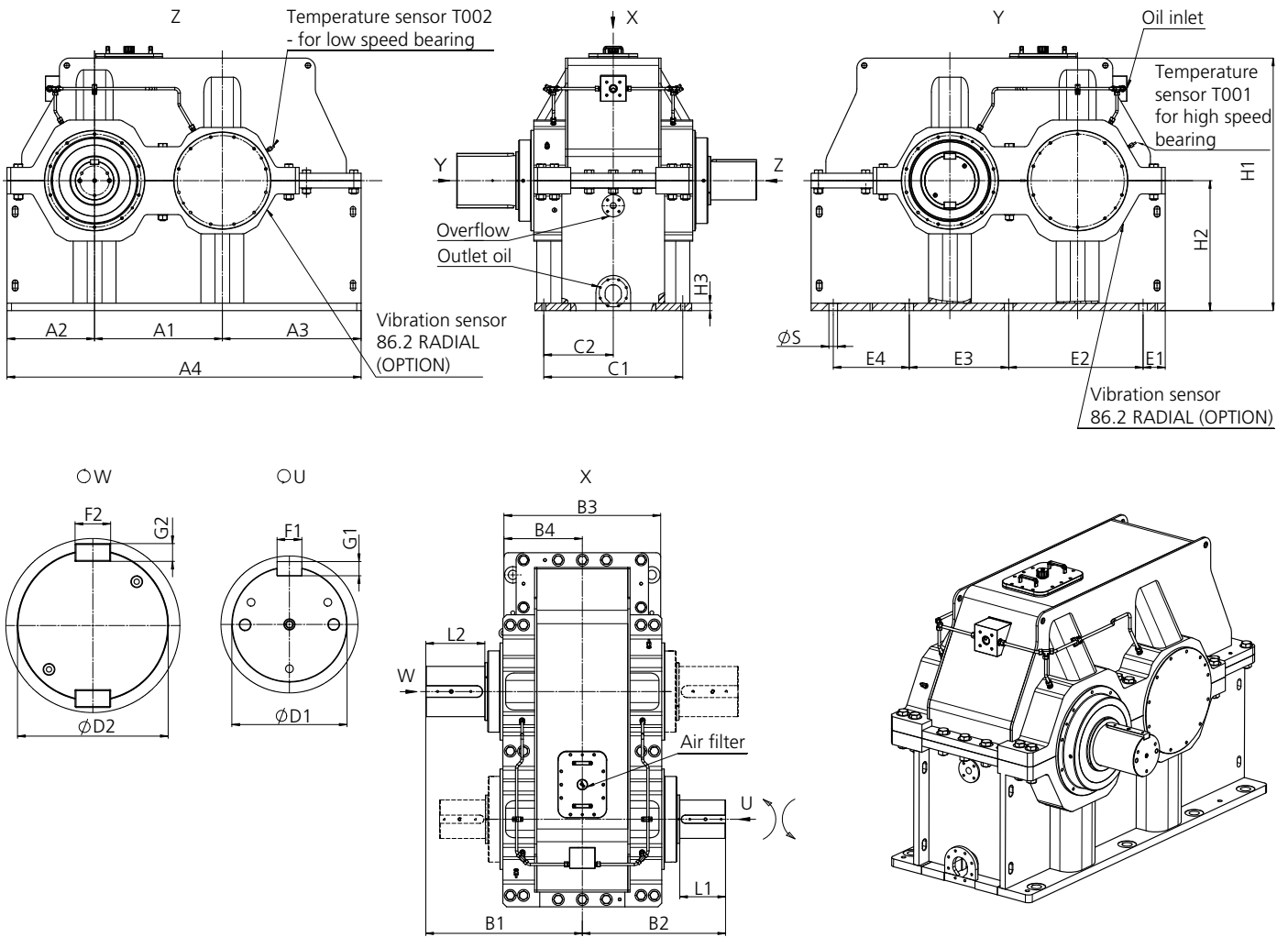

WA gear box catalog																											
Size	Dimension in mm																									Weight kg	
	A1	A2	A3	A4	B1	B2	B3	B4	C1	C2	D1	D2	E1	E2	E3	E4	F1	F2	G1	G2	H1	H2	H3	L1	L2		ØS
WA 575	575	420	685	1680	757	717	775	388	655	328	160	225	150	557	528	345	40	50	22	28	1170	610	50	225	255	30	4060
WA 645	645	460	745	1850	892	802	875	438	755	378	180	260	150	632	598	370	45	56	25	32	1290	670	50	250	320	30	5400
WA 730	730	450	825	2005	982	891	955	478	835	418	200	300	150	665	640	400	45	70	25	36	1480	765	50	275	370	33	6250
WA 790	790	550	875	2215	1002	947	985	493	865	433	240	340	150	795	670	450	56	80	32	40	1560	805	50	310	375	39	7500
WA 865	865	593	940	2398	1060	970	1061	531	941	471	260	340	150	872	711	515	56	80	32	40	1710	880	50	310	400	42	9600
WA 935	935	595	1000	2530	1157	1097	1195	598	1075	538	295	400	150	913	743	575	63	90	32	45	1830	940	50	350	420	45	12500
WA 1000	1000	620	1065	2685	1211	1142	1285	643	1165	583	300	420	150	970	775	640	70	90	36	45	1990	1020	50	355	455	52	15850

Copyright ©2012 FLSmidth A/S. ALL RIGHTS RESERVED. FLSmidth and MAAG are (registered) trademarks of FLSmidth A/S.  
This brochure makes no offers, representations or warranties (express or implied), and information and data contained in  
this brochure are for general reference only and may change at any time.

[www.FLSmidthMaagGear.com](http://www.FLSmidthMaagGear.com)

M 02-13 500-20-ENG

**FLSmidth MAAG Gear AG**

Lagerhausstrasse 11 · P.O. Box  
8401 Winterthur · Switzerland  
Tel +41 52 260 35 00  
Fax +41 52 260 35 35  
[info@FLSmidthMaagGear.com](mailto:info@FLSmidthMaagGear.com)

**FLSMIDTH**  
**MAAG GEAR**