



# Auxill

**Dewateringschroeven**

[www.auxill.nl](http://www.auxill.nl)

## Dewatering screw

The dewatering screw is also a simple machine to dewater sand, grit and other matter that can be settled. The working principle is based on a settle tank and a screw elevator. The elevator transports the waste matter upwards which dewater the solids to be removed.



## Characteristics

- Compact and complete closed.
- Axis free screw makes bearing in the "wet" part unnecessarily.
- Minimal turbulence through applied design.
- Special design overflow gutter prevents constipation through floating material.

### Minimal maintenance through:

- Direct coupled driven unit with internal bearing.
- Small wear of wear plate or wear strip through the low rotations per minute.
- No necessity till bearing and sealing under water.

### How it works

The residue will be upwards transported through the screw. Above the water level, the water stream goes backwards, through which the waste can be transported. The design of the inlet part reduces turbulence till a minimum. Because of this a calm flow patron arises. This is necessary for an optimal waste. The axisfree screw can be driven continuous as discontinues.

## Standard design

The supply funnel and the part of the axis free screw carrier are foreseen by demountable lids. The overflow is foreseen of an inspection hatch. In the trough of the axis free screw carrier are over the entire length wear strips or wear plates placed. The driven units are direct screw coupled at the assemble plate of the axis free part.

Technical data							
Type	flow (l/s)	Water surface (m <sup>2</sup> )	Content (m <sup>3</sup> )	IN (ø mm)	UIT (ø mm)	power (kW)	(Rpm) (min <sup>-1</sup> )
306-OSS-1-SS	1-5	1.3	0.5	100	150	0.25	5.0
306-OSS-2-SS	5-12	2.3	1.2	100	150	0.25	5.0
306-OSS-3-SS	12-20	3.0	1.8	150	200	0.37	4.8
306-OSS-4-SS	20-27	4.0	3.3	200	250	0.75	4.6
306-OSS-5-SS	27-35	5.0	4.2	200	250	0.75	4.6

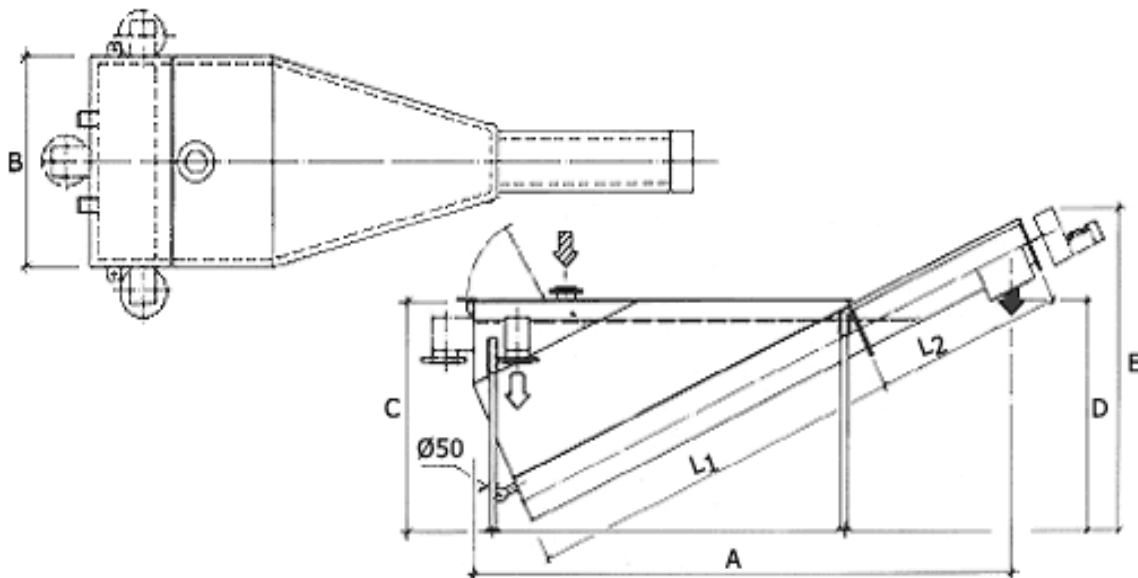

Dimensions							
Type	A (mm)	B (mm)	C* (mm)	D* (mm)	E* (mm)	L1 (mm)	L2* (mm)
* These dimensions are minimum dimensions. Remark: When C and L2 increase, will also A, D and E increase in dimension.							
306-OSS-1-SS	2870	820	1100	1150	1650	2000	1000
306-OSS-2-SS	3840	1170	1500	1550	210	3000	1000
306-OSS-3-SS	4380	1420	1700	1750	2350	3000	1500
306-OSS-4-SS	5890	1420	2150	2400	3050	4000	2000
306-OSS-5-SS	6290	1720	2150	2550	3250	4000	2500

### Used materials

- Funnel, trough and lids: RVS 316L
- Axis free screw: Special steel or alternative stainless steel
- Wear strips or wear plates in different qualities, dependent on the application